

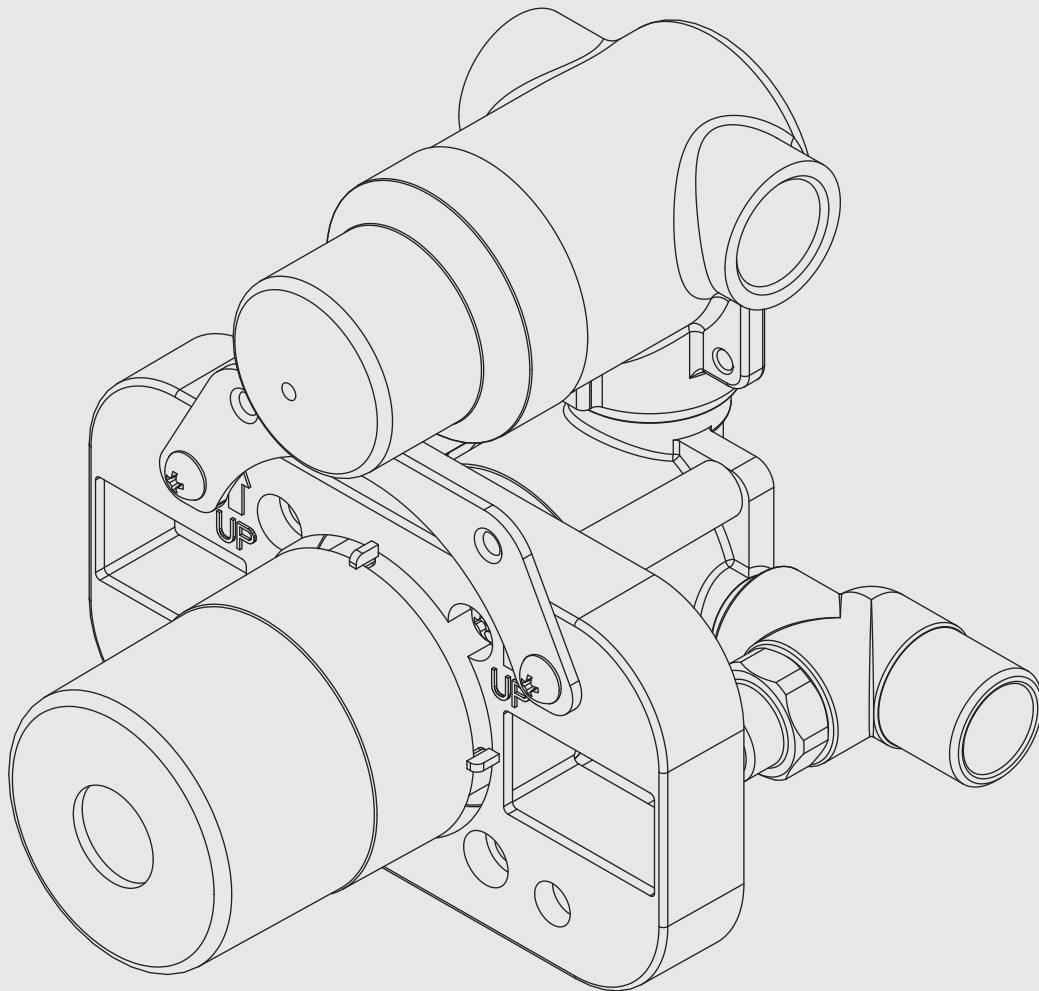

## INSTALLATION INSTRUCTIONS

# M1-4101

TWO HANDLE PRESSURE BALANCE ROUGH WITH 2-WAY DIVERTER, TO  
SUIT M1-4302, M1-4303, X1-2000 & X1-2001, CW-4055 & CB-4065



LEFROY BROOKS

# Dimensions in Inches (& Millimetres)

M1-4102

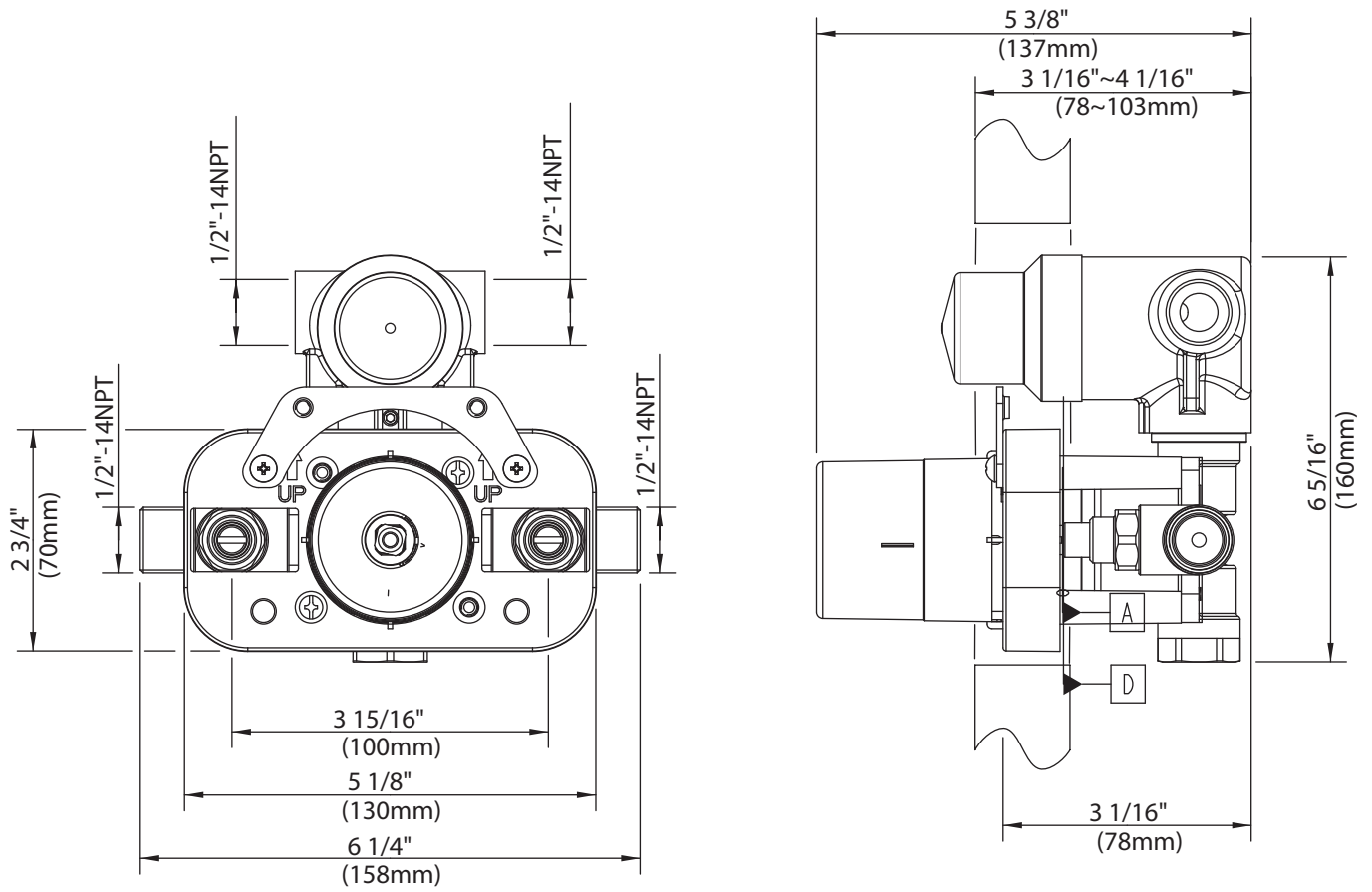

Whilst every effort is made to ensure accuracy, design and dimensions are subject to change without notice as part of the company's product development process.

# What you need to know

## Tools:

Adjustable Wrench  
Groove Joint Pliers  
Hacksaw  
Phillips Screwdriver  
Pipe Tape  
Spatula  
Spirit Level

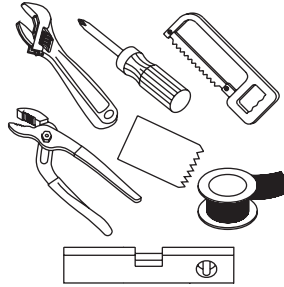

## Maintenance

Your new bathroom faucet is designed for years of trouble-free performance.

Keep it looking new by cleaning it periodically with a soft cloth. Avoid abrasive cleaners, wire wool and harsh chemicals as these will dull the finish and void your warranty.

## Safety Tips

If you are soldering during faucet installation, remove cartridges, seats, gaskets and washers prior to applying flame, otherwise you will void the warranty.

Cover drain openings to avoid losing small parts.

When cutting or soldering pipe, use safety glasses to protect your eyes.

## Important Points

Prior to beginning installation, turn off the cold and hot water lines and open the old faucet to release built-up pressure.

Overtightening nuts may cause damage.

Wrap all threaded connections with pipe tape available at your local plumbing supply store. Always wrap in a clockwise direction. The fittings should be installed by a state-licensed plumber.

Please note:

When there is a difference in water pressure between hot and cold supplies to the mixing valve, the pressures should be equalized by a plumber in accordance with best practice and legislation.

## Things You May Need

Correct installation may vary depending on previous faucet installation. All necessary supplies required for faucet installation are not included, but may be found where plumbing supplies are sold. It is suggested that IAPMO and/or CSA approved plumbing supplies are used during installation.

## Standards

IAPMO/cUPC Listed  
Meets A112.18.1  
Meets ASSE 1016

## Flow Rate

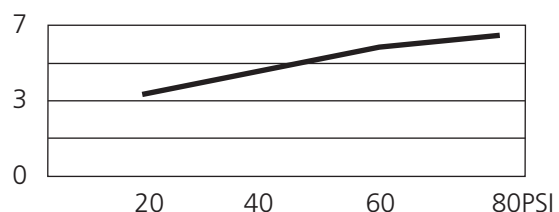

Please note :

Final achievable flow rate is dependent on the outlets fitted, see relevant outlets (spouts, roses, sprays) for fully assembled product flow rate.

# Steps 1-6

## Installation Procedure

Lefroy Brooks always recommends that plumbing products be installed by a licensed professional. Shut off main water supply before installation.

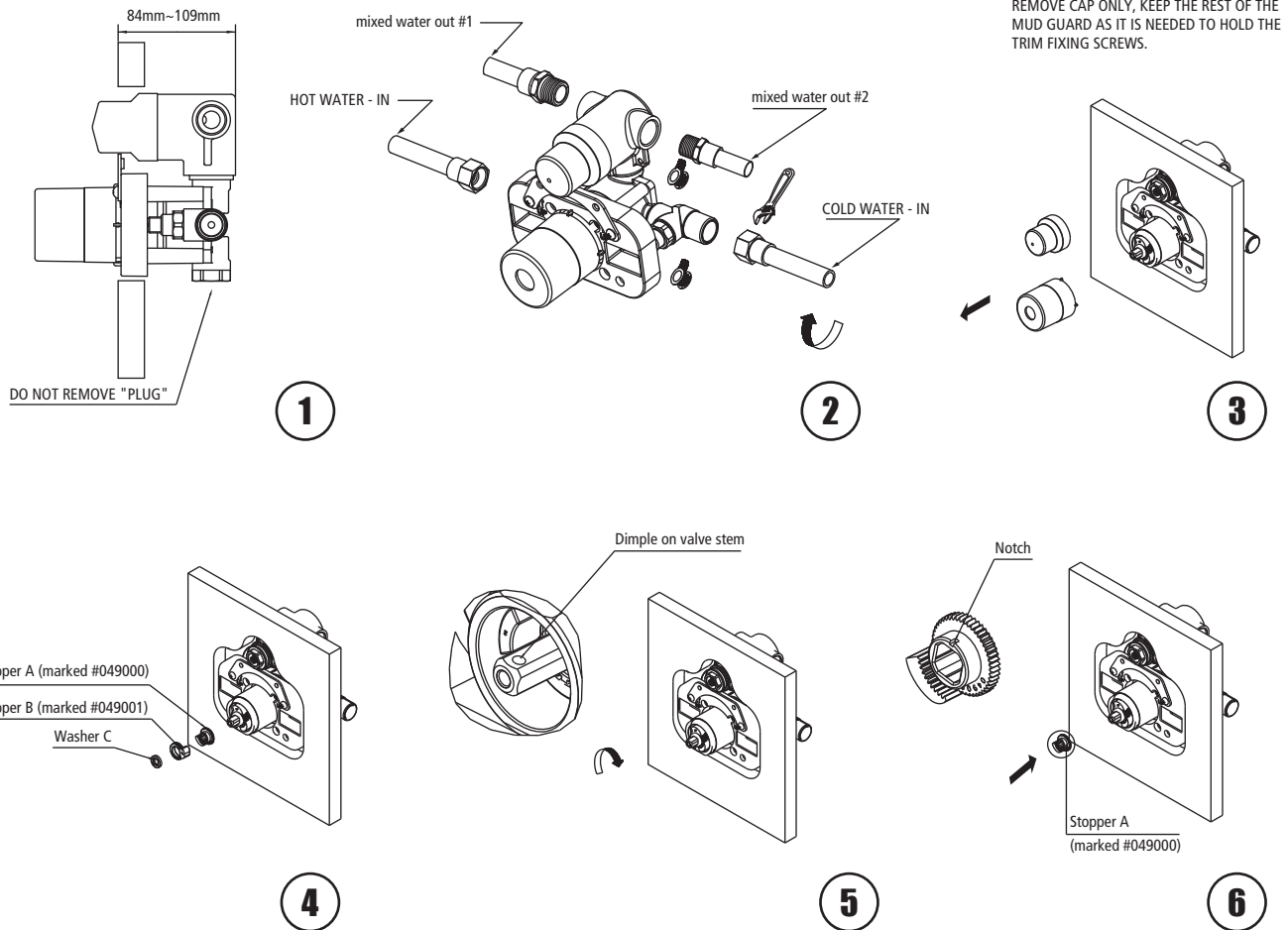

**1** While placing the valve into the wall, make sure that the distance between the wall surface and the back of the valve is between 84~109mm as the figure indicates.

**2** Connect the valve with water pipes.

**3** Throw away the protective cap only when the building construction is completed and you are ready to fit the trim kit in.  
REMOVE CAP ONLY, KEEP THE REST OF THE MUD GUARD AS IT IS NEEDED TO HOLD THE TRIM FIXING SCREWS.

**4** Temperature Limiting Device:  
Remove washer C, then take off stopper A & B.

**5** Turn the valve stem so that the round dimple on the stem is at the top side.

**6** Install stopper A onto valve stem. Notch on stopper A should point upward.

# Steps 7-9

## Installation Procedure

Lefroy Brooks always recommends that plumbing products be installed by a licensed professional. Shut off main water supply before installation.

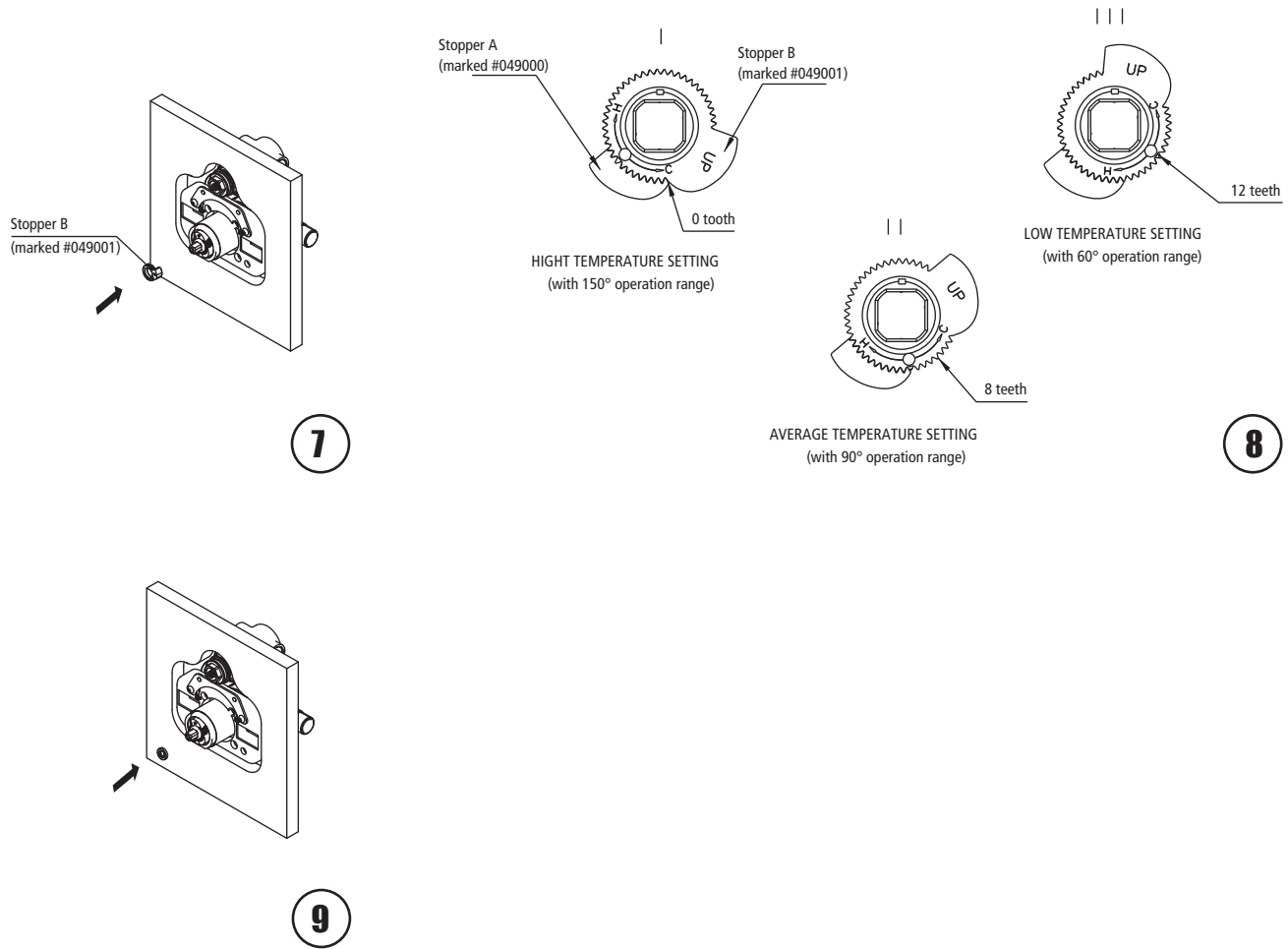

**7** Install stopper B. The word "up" should face out.

**9** Install washer.

**8** Figures I, II, III show how to adjust the temperature limit stop. Having this open at eight notches is recommended.

# Cartridge Gasket

Whenever removing the cartridge always take care to check position of 3-hole rubber gasket (A) which sits in the inside of the cylindrical recess of the rough (B).

Always remove with cartridge to prevent accidental loss of this small part.

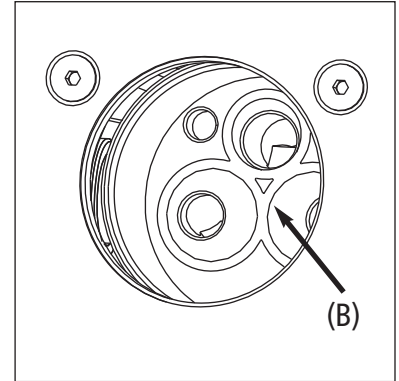
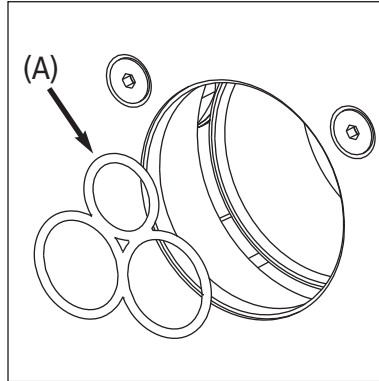
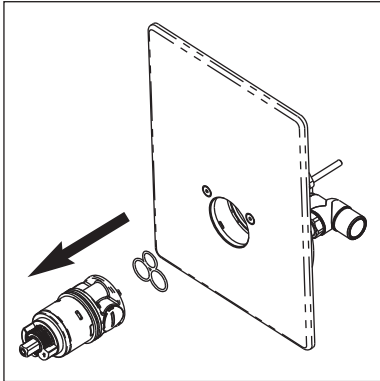

# Cartridge Trouble-Shooting

## PROBLEM

Water temperature is not adjusting.

## CAUSE

Dirty balance spool.

## ACTION

- 1) Take out cartridge (and check 3-hole rubber gasket is not left behind inside the cylindrical recess of the rough).
- 2) Turn slot of plastic cover (C) 90 degree anticlockwise and remove.
- 3) Take out the balance sub-assembly and clean the pressure balance piston (D) with brush and vinegar water. Then re-install the piston and the rest of the sub-assembly into the cartridge. (Please make sure the sub-assembly fits correctly into the cartridge).
- 4) Re-install the plastic cover into the cartridge by turning it 90 degree clockwise.
- 5) Re-install 3-hole rubber gasket.
- 6) Re-install cartridge.

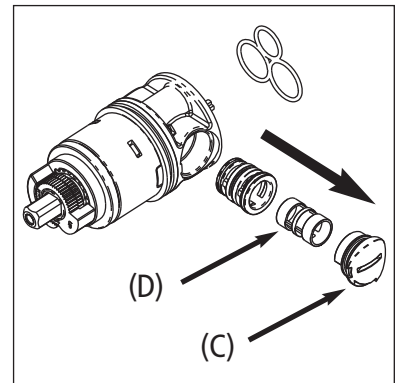

# Exploded View

## Parts List

M1-4102

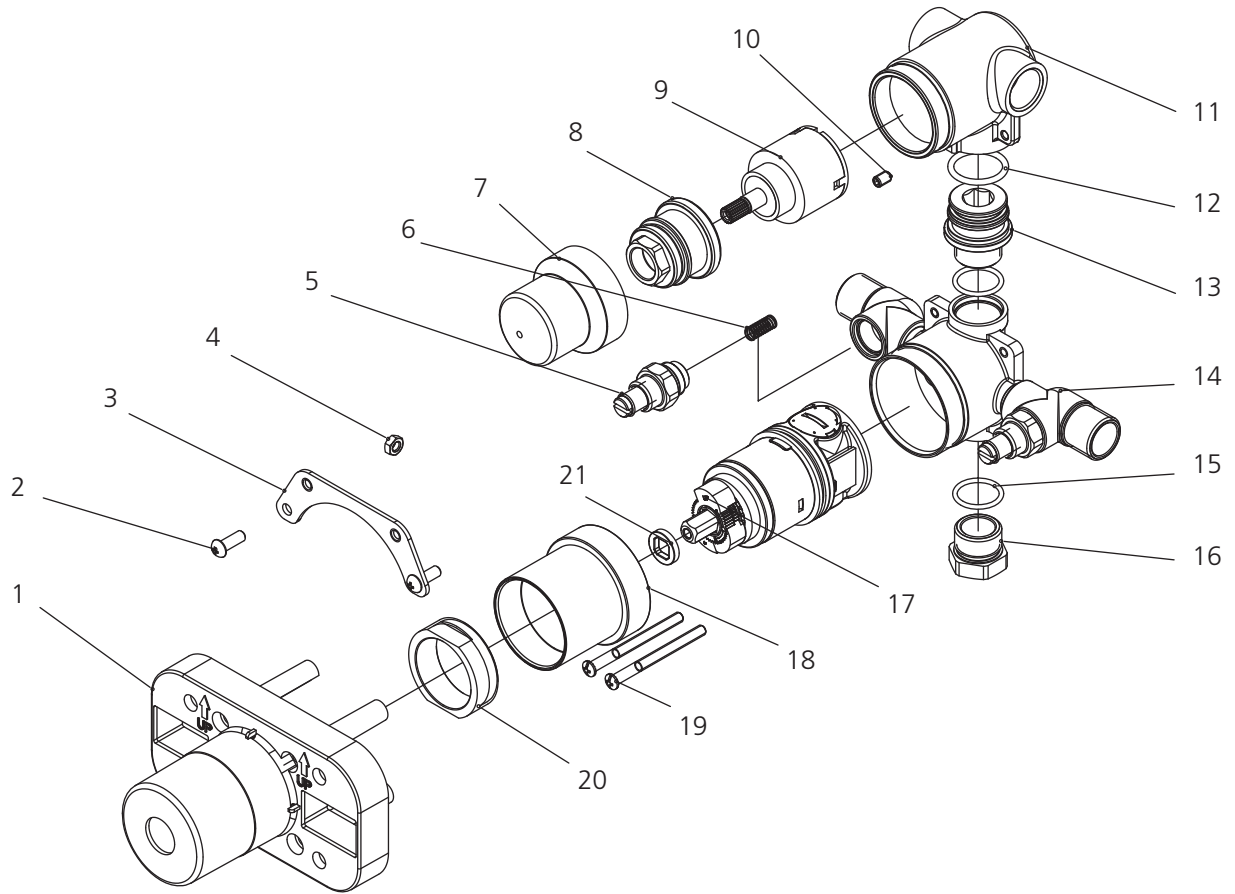

1	Plaster guard (127212)	8	Adjusting ring (104291)	15	O-ring (004074)
2	Screw (075083)	9	Diverter cartridge (507775N)	16	Plug (028599)
3	Fixing board (126055)	10	Set screw (075039)	17	PB cartridge (507655)
4	Nut (009808)	11	Body (076697)	18	Sleeve (041061)
5	Check valve (507037)	12	O-ring (048017)	19	Screw (008241)
6	Spring (005006)	13	Adaptor (057838)	20	Adjusting ring (104105)
7	Protective rubber cap (038008)	14	Body assembly (061847)	21	Washer (013182)

For additional assistance or service call

**718-302-5292**

**9am to 5pm EST Monday to Friday**



LEFROY BROOKS

[www.lefroybrooks.com](http://www.lefroybrooks.com)

LEFROY BROOKS INC, 1828 TROUTMAN STREET, RIDGEWOOD, NY, 11385  
TELEPHONE: 718-302-5292. FAX: 718-302-4177

The use of trademarks, product design and artwork is subject to licence or agreement with LBIP Ltd. The design registrations, trademark registrations and copyrights are protected by law and the use or reproduction outside the terms of an agreement is prohibited. The right to modify designs and dimensions is reserved. Christo Lefroy Brooks is a member of ACID (Anti Copying in Design).