



LEFROY BROOKS

1 8 2 8 T R O U T M A N S T R E E T  
R I D G E W O O D N E W Y O R K N Y 1 1 3 8 5 U S A  
T : + 1 ( 7 1 8 ) 3 0 2 5 2 9 2 F : + 1 ( 7 1 8 ) 3 0 2 4 1 7 7

M1-4716 (ML1517)  
LEVER KITCHEN BRIDGE MIXER

DIMENSIONAL DATA SHEET

DATE: 29 November 2013

No: A66F215W

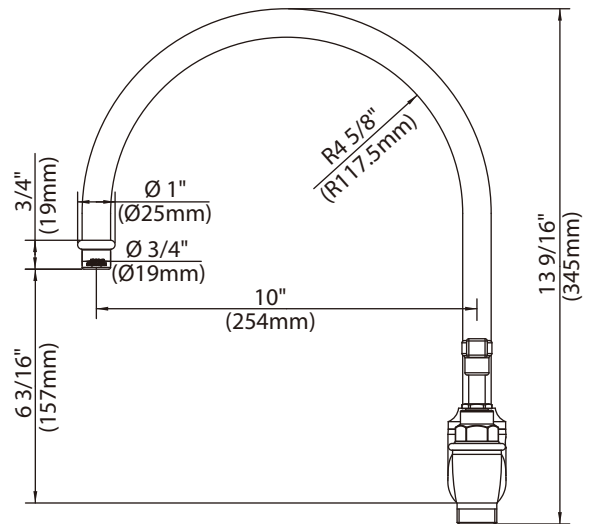
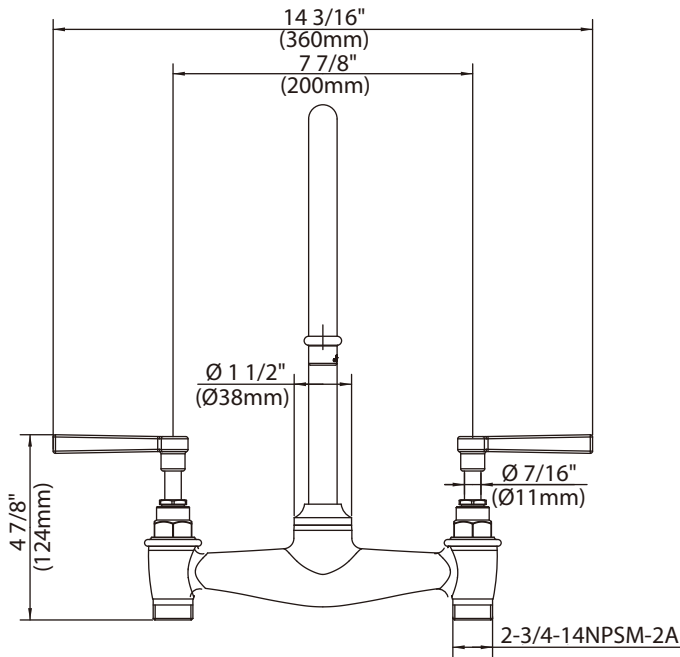

COPYRIGHT © LBIP LTD 2012. ALL RIGHTS RESERVED.

DIMENSIONS IN INCHES & MILLIMETRES

WHILST EVERY EFFORT IS MADE TO ENSURE THE ACCURACY OF THESE DATA SHEETS THEY ARE SUBJECT TO CHANGE WITHOUT NOTICE AS PART OF THE COMPANY'S PRODUCT DEVELOPMENT PROCESS

# M1-4716 (ML1517)

LEVER KITCHEN BRIDGE MIXER

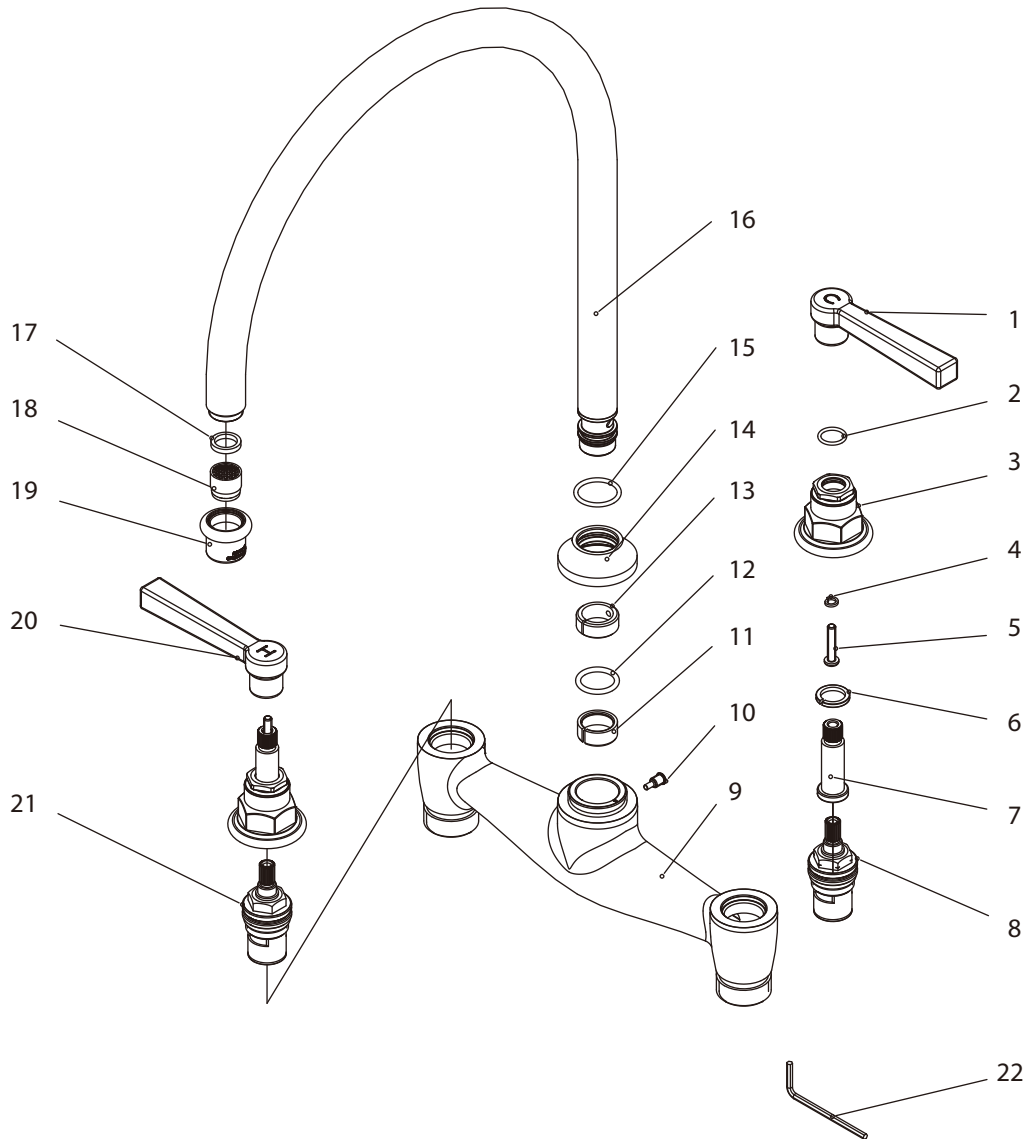

1	Handle ( C ) (029686C-T)	9	Body (002678W)	17	Oil-seal (010519N)
2	O-ring (048085N)	10	Screw (008264)	18	Aerator insert (553661N)
3	Canopy (018253)	11	Clip (012112N)	19	Aerator housing (305849N-54)
4	Washer (013570)	12	O-ring (004005N)	20	Handle ( H ) (029686H-T)
5	Screw (008500)	13	Clip (012060)	21	Cartridge ( H ) (507175W)
6	Clip (012255)	14	Adaptor (018227)	22	Allen Key (031000)
7	Stem extension (110461)	15	O-ring (063066N)		
8	Cartridge ( C ) (507176W)	16	Spout assembly (139889W)		

## Standards

IAPMO/cUPC Listed  
 Meets NSF 61-9  
 Meets A112.18.1  
 ADA Compliant

## Flow Rate

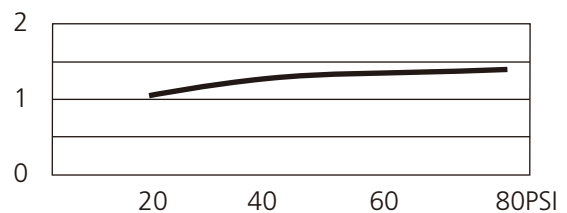

Please note :

Final achievable flow rate is dependent on the outlets fitted, see relevant outlets (spouts, roses, sprays) for fully assembled product flow rate.